



MINIMIZATION, CHARACTERIZATIONS, AND
NONDETERMINISM FOR BIAUTOMATA

Markus Holzer Sebastian Jakobi

IFIG RESEARCH REPORT 1301

APRIL 2013

Institut für Informatik
JLU Gießen
Arndtstraße 2
35392 Giessen, Germany
Tel: +49-641-99-32141
Fax: +49-641-99-32149
mail@informatik.uni-giessen.de
www.informatik.uni-giessen.de

MINIMIZATION, CHARACTERIZATIONS, AND NONDETERMINISM
FOR BIAUTOMATA

Markus Holzer¹ and Sebastian Jakobi²

Institut für Informatik, Universität Giessen
Arndtstraße 2, 35392 Giessen, Germany

Abstract. We show how to minimize biautomata with a Brzowski-like algorithm by applying reversal and powerset construction twice. Biautomata were recently introduced in [O. KLÍMA, L. POLÁK: On biautomata. *RAIRO—Theor. Inf. Appl.*, 46(4), 2012] as a generalization of ordinary finite automata, reading the input from both sides. The correctness of the Brzowski-like minimization algorithm needs a little bit more argumentation than for ordinary finite automata since for a biautomaton its dual or reverse automaton, built by reversing all transitions, does not necessarily accept the reversal of the original language. To this end we first generalize the notion of biautomata to deal with nondeterminism and moreover, to take structural properties of the forward- and backward-transition of the automaton into account. This results in a variety of biautomata models, which accepting power is characterized. As a byproduct we give a simple structural characterization of cyclic regular and commutative regular languages in terms of deterministic biautomata.

Categories and Subject Descriptors: F.1.1 [**Computation by Abstract Devices**]: Models of Computation—*Automata*; F.2.2 [**Analysis of Algorithms and Problem Complexity**]: Nonnumerical Algorithms and Problems—*Computations on discrete structures*; F.4.3 [**Mathematical Logic and Formal Languages**]: Formal Languages—*Classes defined by grammars or automata*;

Additional Key Words and Phrases: deterministic and nondeterministic biautomata, cyclic languages, commutative languages, Brzowski's minimization algorithm.

¹E-mail: holzer@informatik.uni-giessen.de

²E-mail: jakobi@informatik.uni-giessen.de

1 Introduction

Biautomata were recently introduced in [5] as a generalization of ordinary deterministic finite automata. Simply speaking, a biautomaton is a device consisting of a *deterministic* finite control, a read-only input tape, and two reading heads, one reading the input from left to right, and the other head reading the input from right to left. Similar two-head finite automata models were introduced, e.g., in [3, 6, 8]. An input word is accepted by a biautomaton, if there is an accepting computation starting the heads on the two ends of the word meeting somewhere in an accepting state. Although the choice of reading a symbol by either head is nondeterministic, the determinism of the biautomaton is enforced by two properties: (i) The heads read input symbols independently, i.e., if one head reads a symbol and the other reads another, the resulting state does not depend on the order in which the heads read these single letters. (ii) If in a state of the finite control one head accepts a symbol, then this letter is accepted in this state by the other head as well. Later we call the former property the \diamond -property and the latter one the F -property. In [5] it was shown that biautomata share a lot of properties with ordinary deterministic finite automata. For instance, there is a unique (up to isomorphism) minimal deterministic biautomaton for every regular language, which obeys a nice description in terms of two-sided derivatives or quotients—cf. Brzozowski’s construction for ordinary minimal deterministic finite automata [1]. Moreover, simple structural characterizations based on biautomata for language families such as the piecewise testable or prefix-suffix testable languages were given in [5]. Recently in [4] also descriptonal complexity issues for biautomata were addressed. This is the starting point for our investigation.

We focus on the minimization problem for biautomata. For ordinary deterministic finite automata minimization is efficiently solvable. While the algorithm with the best running time of $O(n \log n)$ remains difficult to understand, the most elegant one is that of Brzozowski [2], which minimizes an ordinary finite automaton A , regardless whether it is deterministic or nondeterministic, by applying the reversal and powerset construction twice in sequence. Thus, it computes the automaton $\mathcal{P}([\mathcal{P}(A^R)]^R)$, to obtain an equivalent minimal deterministic finite automaton—here the superscript R refers to the reversal or dual operation on automata and \mathcal{P} denotes the powerset construction. Whether this elegant minimization method can also be applied to a biautomaton A is not completely clear, since the above mentioned two properties to enforce determinism may be lost by computing A^R or $\mathcal{P}(A^R)$. To this end we introduce nondeterministic biautomata. It is known that these machines already accept non-regular languages and characterize the family of linear context-free languages [6], but as a side result we prove that nondeterministic biautomata with the \diamond -property accept regular languages only. In the main line of research we show that a Brzozowski-like minimization of biautomata with \diamond - and F -property, regardless whether they are deterministic or nondeterministic, is possible. Since in Brzozowski’s minimization the powerset construction is used this technique is exponential. Note that it is easy to see that there are more efficient minimization algorithms for *deterministic* biautomata with both the \diamond - and F -property,

by simply adapting other existing minimization algorithms for ordinary deterministic finite automata. As a byproduct of our investigations, we give simple structural characterizations of cyclic regular languages and commutative regular languages in terms of deterministic biautomata with \diamond - and F -property.

The paper is organized as follows: In the next section we introduce the necessary notation on biautomata. In addition we also define an analogous to the F -property, called I -property, which will take care on symbols that are read from an initial state. Then in Section 3 we show some basic properties on these devices. In particular we show that nondeterministic biautomata with the \diamond -property accept regular languages only. Moreover there we also give structural biautomata characterizations of the families of cyclic and of commutative languages. In Section 4 we prove the basics on dual automata, which will then be used in the ultimate section to prove the correctness of the Brzozowski-like minimization for deterministic biautomata with \diamond - and F -property.

2 Preliminaries

We use a more general notion of biautomata than in [5], but it resembles that of nondeterministic linear automata as defined in [6], which characterize the family of linear context-free languages. A *nondeterministic biautomaton* is a sextuple $A = (Q, \Sigma, \cdot, \circ, I, F)$, where Q is a finite set of *states*, Σ is an *alphabet*, $\cdot: Q \times \Sigma \rightarrow 2^Q$ is the *forward transition function*, $\circ: Q \times \Sigma \rightarrow 2^Q$ is the *backward transition function*, $I \subseteq Q$ is the set of *initial states*, and $F \subseteq Q$ is the set of *final* or *accepting states*. The transition functions \cdot and \circ are extended to words in the following way, for all words $v \in \Sigma^*$ and letters $a \in \Sigma$:

$$q \cdot \lambda = \{q\}, \quad q \cdot av = \bigcup_{p \in (q \cdot a)} p \cdot v, \quad \text{and} \quad q \circ \lambda = \{q\}, \quad q \circ va = \bigcup_{p \in (q \circ a)} p \circ v,$$

and further, both \cdot and \circ can be extended to sets of states $S \subseteq Q$, and $w \in \Sigma^*$ by $S \cdot w = \bigcup_{p \in S} p \cdot w$, and $S \circ w = \bigcup_{p \in S} p \circ w$. The biautomaton A *accepts* $w \in \Sigma^*$, if the word w can be written as $w = u_1 u_2 \dots u_k v_k \dots v_2 v_1$, for some $u_i, v_i \in \Sigma^*$ with $1 \leq i \leq k$, such that

$$(((\dots(((I \cdot u_1) \circ v_1) \cdot u_2) \circ v_2) \dots) \cdot u_k) \circ v_k] \cap F \neq \emptyset. \quad (1)$$

The *language accepted* by A is defined as $L(A) = \{w \in \Sigma^* \mid A \text{ accepts } w\}$. A biautomaton A is *deterministic*, if $|I| = 1$, and $|q \cdot a| = |q \circ a| = 1$ for all states $q \in Q$ and letters $a \in \Sigma$. In this case we simply write $q \cdot a = p$, or $q \circ a = p$ instead of $q \cdot a = \{p\}$, or $q \circ a = \{p\}$, respectively, treating \cdot and \circ to be functions mapping $Q \times \Sigma$ to Q . The automaton A has the *confluence* or *diamond property*, for short \diamond -property, if $(q \cdot a) \circ b = (q \circ b) \cdot a$, for every state $q \in Q$ and $a, b \in \Sigma$. Further, A has the *equal acceptance property*, for short F -property, if $q \cdot a \cap F \neq \emptyset$ if and only if $q \circ a \cap F \neq \emptyset$, for every state $q \in Q$ and letter $a \in \Sigma$. A deterministic biautomaton that has both the \diamond - and the F -property is exactly what is called a biautomaton in [5]. Finally, A has the *equal initial fan-out property*, for short I -property, if $I \cdot a = I \circ a$, for every letter $a \in \Sigma$. Two biautomata A and B are *equivalent* if they accept the same language, which means $L(A) = L(B)$.

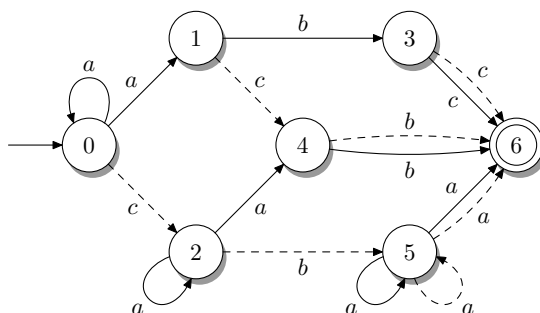

Fig. 1. A nondeterministic biautomaton A , that has both the \diamond - and the F -property, but not the I -property.

holds. Further, we need some notation on languages associated with states of biautomata. For a biautomaton $A = (Q, \Sigma, \cdot, \circ, I, F)$ and a state $q \in Q$ let ${}_q A = (Q, \Sigma, \cdot, \circ, \{q\}, F)$ and $A_q = (Q, \Sigma, \cdot, \circ, I, \{q\})$. We say that $L({}_q A)$ is the *right language* of state q and that $L(A_q)$ is the *left language* of state q . Two states $p, q \in Q$ are *equivalent*, if and only if $L({}_p A) = L({}_q A)$.

We illustrate these definitions by the following example.

Example 1. Consider the nondeterministic biautomaton $A = (Q, \Sigma, \cdot, \circ, I, F)$ with $Q = \{0, 1, \dots, 6\}$, $\Sigma = \{a, b, c\}$, $I = \{0\}$, $F = \{6\}$, and whose transition functions \cdot , and \circ are depicted in Figure 1—solid arrows denote forward transitions by \cdot , and dashed arrows denote backward transitions by \circ . One can check, that A has the \diamond -property, i.e., that $(q \cdot d) \circ e = (q \circ e) \cdot d$, for all inputs $d, e \in \Sigma$ and states $q \in Q$. For example we have

$$(0 \cdot a) \circ c = \{0, 1\} \circ c = \{2, 4\}, \quad \text{and} \quad (0 \circ c) \cdot a = \{2\} \cdot a = \{2, 4\}.$$

Further, A has the F -property, i.e., for all states $q \in Q$, and inputs $d \in \Sigma$ we have $(q \cdot d) \cap F \neq \emptyset$ if and only if $(q \circ d) \cap F \neq \emptyset$. For example both sets $1 \cdot b = \{3\}$, and $1 \circ b = \emptyset$ have an empty intersection with F , and the two sets $5 \cdot a = \{5, 6\}$ and $5 \circ a = \{5, 6\}$ both contain the accepting state 6. However, the biautomaton A does not have the I -property, because $\{0\} \cdot a = \{0, 1\} \neq \emptyset = \{0\} \circ a$. If we removed the backward transition loop on letter a in state 5, i.e., if $5 \circ a = \{6\}$, instead of $5 \circ a = \{5, 6\}$, then A would not have the \diamond -property anymore (because then $(5 \cdot a) \circ a \neq (5 \circ a) \cdot a$), but it would still have the F -property. One observes that the right language of state 2 is $L({}_2 A) = a^*ab$, the left language of state 2 is $L(A_2) = a^*c$, and the language accepted by A is $L(A) = a^*abc$. We will show in Section 3, that a biautomaton with both the \diamond -property, and the F -property accepts a word w if and only if reading w leads from some initial state to a final state, while only using forward transitions. With that result, $L(A)$ can be easily determined in this example. \square

Next we generalize the well known powerset construction of ordinary finite automata to biautomata. For a biautomaton $A = (Q, \Sigma, \cdot, \circ, I, F)$, its *powerset automaton* is the deterministic biautomaton $\mathcal{P}(A) = (Q', \Sigma, \cdot', \circ', q'_0, F')$, where the state set $Q' \subseteq 2^Q$ consists of all states that are reachable from the initial

state $q'_0 = I$, the set of accepting states is $F' = \{P \in Q' \mid P \cap F \neq \emptyset\}$, and the forward and backward transition functions are defined as

$$P \cdot' a = \bigcup_{p \in P} p \cdot a, \quad \text{and} \quad P \circ' a = \bigcup_{p \in P} p \circ a,$$

for every state $P \in Q'$ and letter $a \in \Sigma$.

To prove the correctness of this construction, we use the following simple fact: if $A = (Q, \Sigma, \cdot, \circ, I, F)$ is a nondeterministic biautomaton that has \diamond -property, then $(S \cdot a) \circ b = (S \circ b) \cdot a$, and if A has the F -property, then $(S \cdot a) \cap F \neq \emptyset$ if and only if $(S \circ a) \cap F \neq \emptyset$, for every $S \subseteq Q$ and $a, b \in \Sigma$. Now we prove the following result.

Lemma 2. *If A is a nondeterministic biautomaton, then $\mathcal{P}(A)$ is equivalent to A , i.e., $L(A) = L(\mathcal{P}(A))$. Furthermore, for all $X \in \{\diamond, F, I\}$, if A has the X -property, then the deterministic biautomaton $\mathcal{P}(A)$ has the X -property, too.*

Proof. Let $A = (Q, \Sigma, \cdot, \circ, I, F)$ be a biautomaton, and let its powerset biautomaton be $B = \mathcal{P}(A) = (Q', \Sigma, \cdot', \circ', q'_0, F')$. For $w \in \Sigma^*$, we have $w \in L(A)$ if and only if $w = u_1 u_2 \dots u_k v_k \dots v_2 v_1$, with $u_i, v_i \in \Sigma^*$, $1 \leq i \leq k$, and

$$[\dots (((I \cdot u_1) \circ v_1) \cdot u_2) \circ v_2) \dots] \cdot u_k \circ v_k \cap F \neq \emptyset,$$

and this in turn is equivalent to

$$[\dots (((I \cdot' u_1) \circ' v_1) \cdot' u_2) \circ' v_2) \dots] \cdot' u_k \circ' v_k \in F',$$

which holds if and only if $w \in L(B)$. Thus, $L(A) = L(B)$.

Since the transition functions \cdot' , and \circ' of B are just the extensions of the functions \cdot , and \circ of A to sets of states, the \diamond -property, the F -property, and the I -property are preserved by the powerset construction. \square

We illustrate the construction in the following example.

Example 3. Consider the biautomaton A from Example 1, which is depicted in Figure 1. The powerset biautomaton $\mathcal{P}(A)$, which is a deterministic biautomaton, is shown in Figure 2. Note that since the biautomaton A has both the \diamond -property, and the F -property, also the powerset biautomaton $\mathcal{P}(A)$ has both these properties. \square

3 Basic Properties of Biautomata

In this section we study the effect of the previously defined properties of biautomata. On the one hand, we already know that the most general model of biautomata, namely nondeterministic biautomata without any restrictions, characterizes the family of linear context-free languages [6], while on the other hand, the most restricted biautomaton model, that is, deterministic biautomata with the \diamond - and F -property, describes the family of regular languages [5]. But what else can be said about the accepting power of these devices? To this end, we first take a closer look on the \diamond -property. At first glance, we show that it also extends to words. Recall, that if a biautomaton A with state set Q has the \diamond -property, then $(S \cdot a) \circ b = (S \circ b) \cdot a$, for every subset $S \subseteq Q$ and $a, b \in \Sigma$.

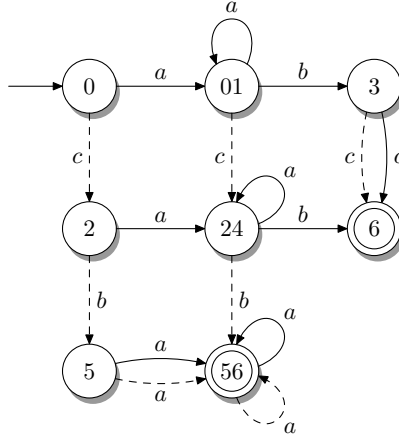

Fig. 2. The powerset biautomaton $\mathcal{P}(A)$ for the nondeterministic biautomaton A from Figure 1. The sink state \emptyset , and transitions leading to it are not shown.

Lemma 4. *Let $A = (Q, \Sigma, \cdot, \circ, I, F)$ be a nondeterministic biautomaton with the \diamond -property. Then $(S \cdot u) \circ v = (S \circ v) \cdot u$, for every $S \subseteq Q$ and $u, v \in \Sigma^*$.*

Proof. First we prove that $(S \cdot a) \circ v = (S \circ v) \cdot a$ holds for every $S \subseteq Q$, word $w \in \Sigma^*$, and $a \in \Sigma$ by induction on the length of v . For $|v| = 0$, that is, for $v = \lambda$, we have $(S \cdot a) \circ v = S \cdot a = (S \circ v) \cdot a$. Now let $|v| \geq 1$. Assume that word v can be written as $v = v'b$, for some $b \in \Sigma$ and $v' \in \Sigma^*$. Then

$$(S \cdot a) \circ v = (S \cdot a) \circ v'b = ((S \cdot a) \circ b) \circ v' = ((S \circ b) \cdot a) \circ v'.$$

Now we can use the inductive assumption on v' and obtain

$$((S \circ b) \cdot a) \circ v' = ((S \circ b) \circ v') \cdot a = (S \circ v'b) \cdot a = (S \circ v) \cdot a.$$

Thus, we have shown $(S \cdot a) \circ v = (S \circ v) \cdot a$, for every $S \subseteq Q$, $a \in \Sigma$, and $v \in \Sigma^*$.

Now we can prove the statement of the lemma by performing induction on the length of the word u . The induction base starts with $|u| = 0$, that is, $u = \lambda$. There we have $(S \cdot u) \circ v = S \circ v = (S \circ v) \cdot u$. Now let $|u| \geq 1$. Assume that u writes as $u = au'$, for some $a \in \Sigma$ and $u' \in \Sigma^*$. Then

$$(S \cdot u) \circ v = (S \cdot au') \circ v = ((S \cdot a) \cdot u') \circ v,$$

and by using first the inductive assumption on u' , and then the statement from above, we obtain

$$((S \cdot a) \cdot u') \circ v = ((S \cdot a) \circ v) \cdot u' = ((S \circ v) \cdot a) \cdot u' = (S \circ v) \cdot au' = (S \circ v) \cdot u,$$

which proves the statement of the lemma. \square

By iteratively using Lemma 4, it follows that for biautomata with the \diamond -property the accepting condition shown in Equation (1) is equivalent to the condition $[(I \cdot u_1 u_2 \dots u_k) \circ v_k \dots v_2 v_1] \cap F \neq \emptyset$, i.e., such a biautomaton accepts a word $w \in \Sigma^*$ if and only if $[(I \cdot u) \circ v] \cap F \neq \emptyset$, for some words $u, v \in \Sigma^*$ with $w = uv$. The acceptance condition becomes even simpler, if the biautomaton additionally has the F -property, which results from the following lemma.

Lemma 5. *Let $A = (Q, \Sigma, \cdot, \circ, I, F)$ be a nondeterministic biautomaton with both the \diamond -property, and the F -property. Then $[(S \cdot uv) \circ w] \cap F \neq \emptyset$ if and only if $[(S \cdot u) \circ vw] \cap F \neq \emptyset$, for every $S \subseteq Q$ and $u, v, w \in \Sigma^*$.*

Proof. We prove the statement by induction on the length of v . Note that the statement holds for $|v| = 0$, since $(S \cdot uv) \circ w = (S \cdot u) \circ vw$, for $v = \lambda$. Now let $|v| \geq 1$. In this case the word v can be written as $v = v'a$, for some $v' \in \Sigma^*$ and letter $a \in \Sigma$. Then by Lemma 4 it follows

$$(S \cdot uv) \circ w = ((S \cdot uv') \cdot a) \circ w = ((S \cdot uv') \circ w) \cdot a.$$

Thus, $[(S \cdot uv) \circ w] \cap F \neq \emptyset$ if and only if $[((S \cdot uv') \circ w) \cdot a] \cap F \neq \emptyset$. Since A has the F -property, the latter holds if and only if $[((S \cdot uv') \circ w) \circ a] \cap F \neq \emptyset$. Observe, that $[((S \cdot uv') \circ w) \circ a]$ is equal to $[(S \cdot uv') \circ aw]$. Now we use the inductive assumption on v' , and see that $[(S \cdot uv') \circ aw] \cap F \neq \emptyset$ if and only if $[(S \cdot u) \circ v'aw] \cap F \neq \emptyset$, which in turn is equivalent to $[(S \cdot u) \circ vw] \cap F \neq \emptyset$, and therefore concludes the proof. \square

By iteratively using Lemma 5, it follows that a biautomaton with both the \diamond -property and the F -property accepts a word $w \in \Sigma^*$ if and only if $[I \cdot w] \cap F \neq \emptyset$, or equivalently, $[I \circ w] \cap F \neq \emptyset$. We summarize this in the following corollary.

Corollary 6. *If A is a nondeterministic biautomaton with both the \diamond -property, and the F -property, then $L(A) = \{w \in \Sigma^* \mid [I \cdot w] \cap F \neq \emptyset\}$. \square*

We can apply Corollary 6 to the biautomaton A from Example 1, and easily see that $L(A) = a^*abc$, by only considering the forward transitions. From Corollary 6, one can see that $L(A)$ is a regular language, if A has both the \diamond -property, and the F -property. But the F -property is not essential here, since already the \diamond -property alone guarantees the regularity of the language $L(A)$, as we show in the following theorem.

Theorem 7. *Let A be a nondeterministic biautomaton with the \diamond -property. Then $L(A)$ is a regular language.*

Proof. Let $A = (Q, \Sigma, \cdot, \circ, I, F)$ be a biautomaton with the \diamond -property. Lemma 4 implies, that A accepts a word $w \in \Sigma^*$ if and only if there are words $u, v \in \Sigma^*$, with $w = uv$, and $[(I \cdot u) \circ v] \cap F \neq \emptyset$. This means that there are $q_0, q, q_f \in Q$, such that $q_0 \in I$, $q \in q_0 \cdot u$, $q_f \in q \circ v$, and $q_f \in F$. Thus, the language $L(A)$ can be described by

$$L(A) = \bigcup_{q \in Q} \{u \mid q \in I \cdot u\} \cdot \{v \mid q \circ v \cap F \neq \emptyset\},$$

and it remains to show that both sets $L_1(q) = \{u \mid q \in I \cdot u\}$, and moreover $L_2(q) = \{v \mid q \circ v \cap F \neq \emptyset\}$ are regular, for every $q \in Q$. The language $L_1(q)$ consists of all the words that, when read forward, lead from some initial state to state q , and language L_2 consists of the words that, when read backwards, lead from state q to some accepting state. Thus, language $L_1(q)$ is accepted by the nondeterministic finite automaton $A_1 = (Q, \Sigma, \delta_1, I, \{q\})$ with $\delta_1(p, a) = p \cdot a$,

for every $p \in Q$ and $a \in \Sigma$ —this shows that $L_1(q)$ is a regular language. Further, the language $L_2(q)^R$ is accepted by the nondeterministic finite automaton $A_2 = (Q, \Sigma, \delta_2, \{q\}, F)$, with $\delta_2(p, a) = p \circ a$, for every $p \in Q$ and $a \in \Sigma$ —since regular languages are closed under reversal, the set $L_2(q)$ is a regular language, too. Since regular languages are closed under concatenation and union, the proof is complete. \square

The following example shows that the language accepted by a biautomaton *without* the \diamond -property may already be non-regular.

Example 8. Let us consider the deterministic biautomaton A , which is defined as $A = (\{0, 1, 2\}, \{a, b\}, \cdot, \circ, \{0\}, \{0\})$, with the transition functions $0 \cdot a = 1$, $1 \circ b = 0$, and all other transitions go to the sink state 2. The biautomaton A is depicted in Figure 3, where the sink state 2, and all transitions leading to it are not shown. This biautomaton does not have the \diamond -property, because $(0 \cdot a) \circ b = 0$, while $(0 \circ b) \cdot a = 2$. The language accepted by A is $L(A) = \{a^n b^n \mid n \geq 0\}$, which is well known to be linear context free but not regular. \square

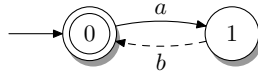

Fig. 3. A deterministic biautomaton without the \diamond -property, that accepts a non-regular language. The sink state 2, and transitions leading to it are not shown.

Of course there are also biautomata that accept regular languages, although they may be missing the \diamond -property. From a descriptive complexity point of view, biautomata without the \diamond -property allow a more succinct representation of a regular language, when compared to biautomata with this property, or compared to deterministic finite automata.

The following example presents a small deterministic biautomaton, such that any equivalent deterministic biautomaton with both the \diamond -property, and the F -property, as well as any equivalent deterministic finite automaton is at least of exponential size.

Example 9. Consider the regular language $L = (a + b)^n \cdot a \cdot (a + b)^* \cdot a \cdot (a + b)^n$, which is accepted by the deterministic biautomaton A , that is depicted in Figure 4. The biautomaton A does neither have the \diamond -property, nor the F -property.

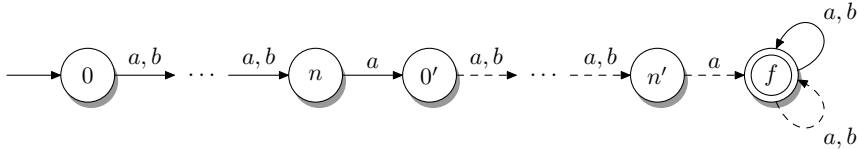

Fig. 4. A linear-size deterministic biautomaton B for the language L . Undefined transitions lead to a non-accepting trap state, which is not shown here.

Further, A has $O(n)$ states, but every equivalent deterministic finite automaton accepting L needs $\Omega(2^n)$ states. Since the minimal deterministic finite automaton is contained in the minimal deterministic biautomaton with both the \diamond -property, and the F -property, also every such biautomaton needs $\Omega(2^n)$ states. But if we abstain from the F -property, the language L can also be accepted by a deterministic biautomaton B with the \diamond -property with $O(n^2)$ states. The states of B are pairs (i, j) , with $i, j \in \{0, 1, \dots, n, f\}$, and additionally, a sink state s , the initial state is $(0, 0)$, the only accepting state is (f, f) , and the transition functions \cdot_B , and \circ_B are defined as follows, for all $i, j \in \{0, 1, \dots, n, f\}$:

$$(i, j) \cdot_B a = \begin{cases} (i+1, j) & \text{if } i \notin \{n, f\}, \\ (f, j) & \text{if } i \in \{n, f\}, \end{cases} \quad (i, j) \circ_B a = \begin{cases} (i, j+1) & \text{if } j \notin \{n, f\}, \\ (i, f) & \text{if } j \in \{n, f\}, \end{cases}$$

$$(i, j) \cdot_B b = \begin{cases} (i+1, j) & \text{if } i \notin \{n, f\}, \\ s & \text{if } i = n, \\ (f, j) & \text{if } i = f, \end{cases} \quad (i, j) \circ_B b = \begin{cases} (i, j+1) & \text{if } j \notin \{n, f\}, \\ s & \text{if } j = n, \\ (i, f) & \text{if } j = f, \end{cases}$$

and the sink state s goes to itself on every transition. This automaton counts the number of symbols it has read from the left in the first component of the state, and the number of symbols it has read from the right in the second component of the state. If a counter reaches n , then the next symbol (in the corresponding reading direction) must be an a . Since the transition function \cdot only operates on the first component of a state, and the function \circ only operates on the second component of a state, one can see that B has the \diamond -property. But since $(f, n) \cdot_B a = (f, n) \neq (f, f) = (f, n) \circ_B a$, the F -property is not present in B .

This example shows that, from a descriptonal complexity point of view, it is expensive to transform a biautomaton that does not have both the \diamond -property, and the F -property into a biautomaton that has both these two properties. \square

It remains to discuss the I -property. If we consider biautomata with the \diamond -property, and the I -property, then switching from \cdot to \circ when reading a subword induces a circular shift on the word, which can be seen in the following lemma.

Lemma 10. *Let $A = (Q, \Sigma, \cdot, \circ, I, F)$ be a nondeterministic biautomaton with both the \diamond -property, and the I -property. Then $(I \cdot uv) \circ w = (I \cdot v) \circ wu$, for every $u, v, w \in \Sigma^*$.*

Proof. We use induction on the length of u . For $|u| = 0$, that is, in case $u = \lambda$ we have $(I \cdot uv) \circ w = (I \cdot v) \circ w = (I \cdot v) \circ wu$. Now let $|u| \geq 1$ and assume that $u = au'$, for some $a \in \Sigma$ and $u' \in \Sigma^*$. By Lemma 4, and the I -property, we have

$$(I \cdot uv) \circ w = ((I \cdot a) \cdot u'v) \circ w = ((I \circ a) \cdot u'v) \circ w = ((I \cdot u'v) \circ a) \circ w = (I \cdot u'v) \circ wa,$$

and then the proof can be concluded by using the inductive assumption on u' to obtain

$$(I \cdot u'v) \circ wa = (I \cdot v) \circ wau' = (I \cdot v) \circ wu,$$

which concludes the proof. \square

Lemma 10 implies that the *left language* of every state q , i.e., the set of words leading to q , in a biautomaton with both the \diamond -property, and the I -property is cyclic. Here a language $L \subseteq \Sigma^*$ is cyclic if and only if $L = \circ(L)$, where $\circ(L) = \{vu \in \Sigma^* \mid uv \in L\}$. In particular, this implies the following result.

Corollary 11. *Let A be a nondeterministic biautomaton with both the \diamond - and the I -property, then $L(A)$ is a regular cyclic language. \square*

In fact, for the canonical biautomaton, which is the minimal deterministic biautomaton that has both the \diamond -property, and the F -property [5], also the converse implication holds. For a regular language $L \subseteq \Sigma^*$ we define the *canonical biautomaton* $A_L = (Q_L, \Sigma, \cdot_L, \circ_L, I_L, F_L)$ with $Q_L = \{u^{-1}Lv^{-1} \mid u, v \in \Sigma^*\}$, initial states $I_L = \{L\}$, final states $F_L = \{u^{-1}Lv^{-1} \mid \lambda \in u^{-1}Lv^{-1}\}$, and $q \cdot_L a = a^{-1}q$ and $q \circ_L a = qa^{-1}$, where $u^{-1}Lv^{-1} = \{w \in \Sigma^* \mid uww \in L\}$, for $u, v \in \Sigma^*$. Thus we obtain the following characterization of regular cyclic languages.

Theorem 12. *A regular language is cyclic if and only if its canonical biautomaton has the I -property.*

Proof. If A is a biautomaton, not necessarily the canonical one, but with the I -property, then we know from Corollary 11, that $L(A)$ is a regular cyclic language. For the converse implication, let $L \subseteq \Sigma^*$ be a regular cyclic language, and let $A_L = (Q, \Sigma, \cdot, \circ, \{q_0\}, F)$ be its canonical biautomaton with $q_0 = L$. Since L is cyclic, for every word $v \in \Sigma^*$ and $a \in \Sigma$, we have $av \in L$ if and only if $va \in L$. Thus, for every $a \in \Sigma$, we obtain $q_0 \cdot a = a^{-1}L = \{v \in \Sigma^* \mid av \in L\}$ which is equal to the set $\{v \in \Sigma^* \mid va \in L\} = La^{-1} = q_0 \circ a$, so A has the I -property. This proves the stated claim. \square

We can also characterize commutative regular languages by the structure of their canonical biautomaton. A regular language $L \subseteq \Sigma^*$ is *commutative* if for all words $u, v \in \Sigma^*$ and symbols $a, b \in \Sigma$ we have $uabv \in L$ if and only if $ubav \in L$. One can see by induction that this condition is equivalent to the condition that for all words $u, v, x, y \in \Sigma^*$ we have $uxyv \in L$ if and only if $uyxv \in L$.

Theorem 13. *Let $L \subseteq \Sigma^*$ be a regular language and $A = (Q, \Sigma, \cdot, \circ, I, F)$ its canonical biautomaton. Then L is commutative if and only if $q \cdot a = q \circ a$, for every $q \in Q$ and $a \in \Sigma$.*

Proof. Let $L \subseteq \Sigma^*$ be a regular language, and let $A = (Q, \Sigma, \cdot, \circ, I, F)$ be the canonical biautomaton of L , with $q \cdot a = q \circ a$, for all $q \in Q$ and $a \in \Sigma$. Then, by Corollary 11, all the right languages $L(qA)$ of states $q \in Q$ are cyclic, since qA has the I -property. Since the right languages of states of the canonical biautomaton are quotients $u^{-1}Lv^{-1}$, for $u, v \in \Sigma^*$, all these quotients are cyclic. Thus, for all $u, v, x, y \in \Sigma^*$ we have $xy \in u^{-1}Lv^{-1}$ if and only if $yx \in u^{-1}Lv^{-1}$. It follows that L is commutative.

For the converse, assume L is commutative, and consider a symbol $a \in \Sigma$, and a state $q \in Q$ that corresponds to a quotient $u^{-1}Lv^{-1}$, for some $u, v \in \Sigma^*$.

Then we have

$$\begin{aligned} q \cdot a &= [u^{-1}Lv^{-1}] \cdot a = (ua)^{-1}Lv^{-1} = \{x \in \Sigma^* \mid uaxv \in L\}, \\ q \circ a &= [u^{-1}Lv^{-1}] \circ a = u^{-1}L(av)^{-1} = \{x \in \Sigma^* \mid uxav \in L\}, \end{aligned}$$

and since L is commutative, it follows $q \cdot a = q \circ a$. \square

Note that the condition $q \cdot a = q \circ a$ together with the \diamond -property in particular implies that $(q \cdot a) \cdot b = (q \cdot b) \cdot a$ holds for the forward transition function of the canonical biautomaton. This nicely shows the connection to commutative finite automata [7], where $\delta(q, ab) = \delta(q, ba)$ holds for the transition function δ of the finite automaton.

4 The Dual of a Biautomaton

For classical finite automata, an automaton for the reversal of the accepted language can be obtained by constructing the reversal, or dual automaton, i.e., by reversing the transitions, and interchanging initial and final states. For biautomata, one obtains an automaton for the reversal of the language by simply interchanging the transition functions \cdot and \circ . Nevertheless, it is interesting to see what happens, if we apply a similar construction as for finite automata to biautomata. We will see in Section 5, that similar to finite automata, the dual of a biautomaton can be used to construct a minimal biautomaton. Now let us define the *reversal*, or *dual* of the biautomaton $A = (Q, \Sigma, \cdot, \circ, I, F)$ as the biautomaton $A^R = (Q, \Sigma, \cdot^R, \circ^R, F, I)$, that is obtained from A by interchanging the initial and final states, and by reversing all transitions, such that $p \in q \cdot^R a$ if and only if $q \in p \cdot a$, and $p \in q \circ^R a$ if and only if $q \in p \circ a$. Note that $(A^R)^R = A$.

Lemma 14. *Let $A = (Q, \Sigma, \cdot, \circ, I, F)$ be a nondeterministic biautomaton, and let $A^R = (Q, \Sigma, \cdot^R, \circ^R, F, I)$ be the dual of A . Then for every states $p, q \in Q$ and words $u, v \in \Sigma^*$, we have $q \in (p \cdot u) \circ v$ if and only if $p \in (q \circ^R v^R) \cdot^R u^R$, and $q \in (p \circ v) \cdot u$ if and only if $p \in (q \cdot^R u^R) \circ^R v^R$.*

Proof. We prove the first part of the statement, namely $q \in (p \cdot u) \circ v$ if and only if $p \in (q \circ^R v^R) \cdot^R u^R$, by induction on $|uv|$. The second part of the statement then follows by symmetric argumentation, since $(A^R)^R = A$. For $|uv| = 0$, i.e., for $u = v = \lambda$, we have $(p \cdot u) \circ v = \{p\} = (p \circ^R v^R) \cdot^R u^R$, so the statement holds in this case. Now let $|uv| \geq 1$, then we have $uv = u'av'$, with $u', v' \in \Sigma^*$, and $a \in \Sigma$, such that either $u = u'a$, or $v = av'$. First consider the case $u = u'a$. Then we have $q \in (p \cdot u) \circ v$ if and only if there are states $p_1, p_2 \in Q$, such that $p_1 \in p \cdot u'$, $p_2 \in p_1 \cdot a$, and $q \in p_2 \circ v$. Now we can apply the inductive assumption on the words u' , and v , since both are shorter than $uv = u'av'$, and see that $p_1 \in p \cdot u'$ holds if and only if $p \in p_1 \cdot^R u'^R$, and $q \in p_2 \circ v$ holds if and only if $p_2 \in q \circ^R v^R$. Further, by definition of \cdot^R , we have $p_2 \in p_1 \cdot a$ if and only if $p_1 \in p_2 \cdot^R a$. Putting all this together, we have $q \in (p \cdot u) \circ v$ if and only if there are states $p_1, p_2 \in Q$, such that $p_2 \in q \circ^R v^R$, $p_1 \in p_2 \cdot^R a$, and $p \in p_1 \cdot^R u'^R$, i.e., if and only if $p \in (q \circ^R v^R) \cdot^R u^R$. The other case, $v = av'$ can be shown similarly: $q \in (p \cdot u) \circ v = ((p \cdot u) \circ v') \circ a$ if and only if there is a state $p_1 \in Q$,

such that $p_1 \in (p \cdot u) \circ v'$, and $q \in p_1 \circ a$. By the inductive assumption, we have $p_1 \in (p \cdot u) \circ v'$ if and only if $p \in (p_1 \circ^R v'^R) \cdot^R u^R$, and by the definition of \circ^R , we have $q \in p_1 \circ a$ if and only if $p_1 \in q \circ^R a^R$. Thus, we have $q \in (p \cdot u) \circ v$ if and only if $p \in ((q \circ^R a^R) \circ^R v'^R) \cdot^R u^R = (q \circ^R v^R) \cdot^R u^R$. \square

Note that if A has the \diamond -property, then the statement of Lemma 14 can be simplified to $q \in (p \cdot u) \circ v$ if and only if $p \in (q \cdot^R u^R) \circ^R v^R$.

Lemma 15. *Let A be a nondeterministic biautomaton, then the following holds:*

1. *A has the \diamond -property if and only if A^R has the \diamond -property.*
2. *A has the F -property if and only if A^R has the I -property.*
3. *A has the I -property if and only if A^R has the F -property.*

Proof. Let $A = (Q, \Sigma, \cdot, \circ, I, F)$ be a biautomaton, and $A^R = (Q, \Sigma, \cdot^R, \circ^R, F, I)$ be its dual. Assume A has the \diamond -property, i.e., $(q \cdot a) \circ b = (q \circ b) \cdot a$, for every $q \in Q$ and $a, b \in \Sigma$. To see that A^R has the \diamond -property, consider a state $q \in Q$, and note that by Lemma 14 we have $(q \cdot^R a) \circ^R b = \{p \in Q \mid q \in (p \circ b) \cdot a\}$. Since A has the \diamond -property, we know that $\{p \in Q \mid q \in (p \circ b) \cdot a\} = \{p \in Q \mid q \in (p \cdot a) \circ b\}$, and by using Lemma 14 again, we obtain $\{p \in Q \mid q \in (p \cdot a) \circ b\} = (q \circ^R b) \cdot^R a$. Thus, we have shown $(q \cdot^R a) \circ^R b = (q \circ^R b) \cdot^R a$, for every $q \in Q$ and $a, b \in \Sigma$. We have shown that the \diamond -property of A implies the \diamond -property of A^R . The reverse implication immediately follows, since $(A^R)^R = A$, so the first statement is proven.

Now we show that the F -property of A implies the I -property of A^R . If A has the F -property, then $\{q \in Q \mid (q \cdot a) \cap F \neq \emptyset\} = \{q \in Q \mid (q \circ a) \cap F \neq \emptyset\}$, for every $a \in \Sigma$. Since by Lemma 14 we have

$$F \cdot^R a = \bigcup_{f \in F} f \cdot^R a = \bigcup_{f \in F} \{q \in Q \mid f \in q \cdot a\} = \{q \in Q \mid (q \cdot a) \cap F \neq \emptyset\}$$

and

$$F \circ^R a = \bigcup_{f \in F} f \circ^R a = \bigcup_{f \in F} \{q \in Q \mid f \in q \circ a\} = \{q \in Q \mid (q \circ a) \cap F \neq \emptyset\},$$

the dual A^R has the I -property—note that F is the set of initial states of A^R . For the reverse implication note that $(q \cdot a) \cap F \neq \emptyset$ if and only if $q \in F \cdot^R a$, and if A^R has the I -property, then $q \in F \cdot^R a$ if and only if $q \in F \circ^R a$, and the latter again holds if and only if $(q \circ a) \cap F \neq \emptyset$. Thus, the second statement is proven. The final statement now follows from the fact that $(A^R)^R = A$. \square

If we have a biautomaton A with both the \diamond - and the F -property, then Lemma 15 implies that the dual of the biautomaton A has the \diamond - and the I -property. Further, Lemma 10 implies, that the language accepted by the dual is cyclic. In fact, we can show the following result.

Corollary 16. *Let $A = (Q, \Sigma, \cdot, \circ, I, F)$ be a nondeterministic biautomaton that has both the \diamond - and the F -property, and let $A^R = (Q, \Sigma, \cdot^R, \circ^R, F, I)$ be the dual of A . Then $L(A^R) = \circ(L(A)^R)$, i.e., automaton A^R accepts the cyclic shift of the reversal of $L(A)$.*

Proof. Let $w \in L(A)$, then by Corollary 6, we have $(I \cdot w) \cap F \neq \emptyset$, i.e., there is a state $p \in I$, and a state $q \in F$, such that $q \in p \cdot w$. By Lemma 14, this is equivalent to $p \in q \cdot^R w^R$, which means that w^R is accepted by A^R . Since by Corollary 11, the language $L(A^R)$ is cyclic, we know that $\circlearrowleft(w^R) \subseteq L(A^R)$, for every $w \in L(A)$, so $\circlearrowleft(L(A)^R) \subseteq L(A^R)$. For the other inclusion let $w \in L(A^R)$, then we know that there are words $u, v \in \Sigma^*$, with $uv = w$, such that $q_0 \in (q_f \cdot^R u) \circ^R v$, for some $q_f \in F$, and $q_0 \in I$. Lemma 10 implies that also $q_0 \in q_f \cdot^R vu$, which is equivalent to $q_f \in q_0 \cdot^R (vu)^R$, by Lemma 14. This means that $(vu)^R$ is accepted by A , so $vu \in L(A)^R$. Since $w = uv \in \circlearrowleft(vu)$, we have $w \in \circlearrowleft(L(A)^R)$. \square

What can be said about $L(A^R)$, if A is a biautomaton with both the \diamond - and the I -property? Unfortunately, the language cannot be identified by some operation on the language $L(A)$, because a regular cyclic language can be accepted by structurally different biautomata that have the \diamond - and the I -property. From these structural differences, also different dual automata, that accept different languages, can result, as the following example shows.

Example 17. Consider the cyclic language $L = \{ab, ba\}$, which is accepted by all the three biautomata A_1, A_2 , and A_3 , that are depicted in Figure 5. Note that

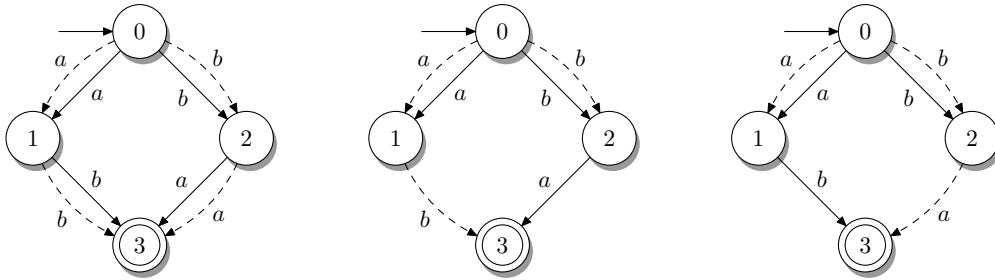

Fig. 5. Three different nondeterministic biautomata A_1 (left), A_2 (middle), and A_3 (right), all accepting the language $\{ab, ba\}$.

these three automata have both the \diamond - and the I -property. The corresponding dual automata A_1^R, A_2^R , and A_3^R are depicted in Figure 6. Note that these three automata have both the \diamond - and the F -property. Further note, that the languages $L(A_1^R) = \{ab, ba\}$, $L(A_2^R) = \{ab\}$, and $L(A_3^R) = \{ba\}$ accepted by the dual automata are pairwise distinct. \square

5 Brzowski-Like Minimization for Biautomata

An interesting algorithm for minimizing deterministic finite automata is that of Brzowski [2]: given a (deterministic or nondeterministic) finite automaton A , it computes $\mathcal{P}([\mathcal{P}(A^R)]^R)$, which turns out to be the minimal deterministic finite automaton for $L(A)$. While the minimality of the constructed automaton needs some argumentation, the facts that it accepts the correct language, and that it is a deterministic finite automaton are easy to see, since the dual B^R

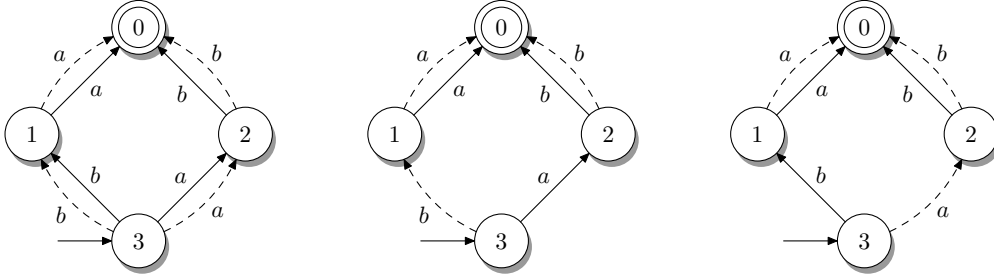

Fig. 6. The dual automata A_1^R (left), A_2^R (middle), and A_3^R (right) of the corresponding biautomata from Figure 5 accepting pairwise different languages.

of a finite automaton B accepts the reverse of the language accepted by B , i.e., $L(B^R) = L(B)^R$. We have seen in the Section 4, that the relation between the languages accepted by a biautomaton A and its dual A^R is not as simple as for classical finite automata. Nevertheless we can show that Brzozowski's minimization algorithm can still be used for minimization of biautomata. More precisely, we prove that for every (deterministic or nondeterministic) biautomaton A with both the \diamond - and the F -property, the automaton $\mathcal{P}([\mathcal{P}(A^R)]^R)$ is the unique minimal deterministic biautomaton, that has both the \diamond - and the F -property. Note that the middle automaton $\mathcal{P}(A^R)$ is a deterministic biautomaton, that has the I -property. The following lemma starts with this middle automaton.

Lemma 18. *Let A be a deterministic biautomaton with both the \diamond - and the I -property, and with no unreachable states. Then $\mathcal{P}(A^R)$ is a minimal biautomaton with both the \diamond - and the F -property.*

Proof. Let $A = (Q, \Sigma, \cdot, \circ, q_0, F)$ be a deterministic biautomaton with both the \diamond - and the I -property, where all states $q \in Q$ are reachable. Further, let $A^R = (Q, \Sigma, \cdot^R, \circ^R, F, \{q_0\})$ be its dual biautomaton, and let $B = \mathcal{P}(A^R)$ be the powerset biautomaton of A^R . Assume that $B = (Q_B, \Sigma, \cdot_B, \circ_B, q_0^B, F_B)$. Lemmas 2 and 15 imply that B has both the \diamond - and the F -property. In the following, we prove that B does not have a pair of distinct, but equivalent states. Since by definition of \mathcal{P} all states in $B = \mathcal{P}(A^R)$ are reachable, the minimality of B then follows from [5].

Let $P_1, P_2 \in Q_B$ be two distinct states of B , then we may assume that there is an element $q \in Q$, with $q \in P_1 \setminus P_2$. Since q is reachable in the deterministic biautomaton A , there are words $u, v \in \Sigma^*$, such that $q = (q_0 \cdot u) \circ v$. Since A has both the \diamond - and the I -property, Lemma 10 implies $q = q_0 \cdot vu$. This means that in the dual automaton A^R , we have $q_0 \in q \cdot^R (vu)^R$, by Lemma 14. Furthermore, this means that in the powerset biautomaton B we have $q_0 \in (P_1 \cdot_B (vu)^R)$, because $q \in P_1$. Since the accepting states of B are the sets $P \in Q_B$ with $q_0 \in P$, it follows that the word $(vu)^R$ is accepted by B , when starting from state P_1 . Now assume, for the sake of contradiction, that $(vu)^R$ is also accepted by B , when starting from state P_2 . Then, since B has the \diamond - and the F -property, we know from Corollary 6, that $q_0 \in P_2 \cdot_B (vu)^R$, i.e., that there is a state $p \in P_2$, with $q_0 \in p \cdot^R (vu)^R$. From Lemma 14, and the fact that A is deterministic,

we obtain $p = q_0 \cdot vu = q$, which is a contradiction to $q \notin P_2$. We have shown that $(vu)^R$ is accepted by B when starting from state P_1 , but not when starting from state P_2 , so P_1 and P_2 cannot be equivalent. \square

Now we are able to prove the main result of this section.

Theorem 19. *Let A be a (deterministic or nondeterministic) biautomaton with both the \diamond - and the F -property. Then $\mathcal{P}([\mathcal{P}(A^R)]^R)$ is the unique minimal biautomaton with both the \diamond - and F -property, for the language $L(A)$.*

Proof. Let $A = (Q, \Sigma, \cdot, \circ, I, F)$ be a biautomaton with both the \diamond - and the F -property. Then let $B = \mathcal{P}(A^R)$ and $C = \mathcal{P}(B^R)$, where we assume that $B = (Q_B, \Sigma, \cdot_B, \circ_B, q_0^B, F_B)$, and $C = (Q_C, \Sigma, \cdot_C, \circ_C, q_0^C, F_C)$. Then B is a deterministic biautomaton with the \diamond - and the I -property, with no unreachable states. So by Lemma 18, the automaton C is a minimal biautomaton with the \diamond - and the F -property. It follows from [5], that C is the unique minimal automaton, among all biautomata with these two properties, accepting $L(C)$. It remains to prove $L(A) = L(C)$, which, due to Corollary 6, can be done by only reasoning about forward transitions: For all words $w \in \Sigma^*$, we have $w \in L(A)$ if and only if $(I \cdot w) \cap F \neq \emptyset$. By Lemma 14, this holds if and only if $(F \cdot^R w^R) \cap I \neq \emptyset$, which is the same as $q_0^B \cdot_B w^R \in F_B$, by definition of B . We again use Lemma 14, to see that $q_0^B \cdot_B w^R \in F_B$ holds if and only if $q_0^B \in F_B \cdot_B^R w$, which by definition of C is equivalent to $q_0^C \cdot_C w \in F_C$. Thus, we have $w \in L(A)$ if and only if $w \in L(C)$. \square

We illustrate the algorithm in the following example.

Example 20. Let $A = (Q, \{a, b\}, \cdot, \circ, I, F)$ be a nondeterministic biautomaton with $Q = \{0, 1, 2, 3, 4\}$, $I = \{0, 1\}$, $F = \{1, 4\}$, and whose transition functions \cdot , and \circ are depicted on the left in Figure 7. Note that A has both the \diamond - and the F -property. The corresponding powerset biautomaton $B = \mathcal{P}(A^R)$ of the dual of A is depicted in the middle in Figure 7. Finally, the minimal deterministic biautomaton $C = \mathcal{P}(B^R)$ is depicted on the right in Figure 7, where again the sink state \emptyset , and all transitions leading to it are omitted. Let us follow the argumentation in the proof of Lemma 18, to show that the states p and s cannot be equivalent. Note that $p = \{\{0\}, \{1, 3\}, \{1, 4\}\}$, and $s = \{\{1, 3\}, \{1, 4\}\}$ differ in the element $\{0\}$, which is reachable in the biautomaton B , for example by first reading a with a forward transition, and then b with a backward transition: $(\{1, 4\} \cdot a) \circ b = \{0\}$. One can check that by Lemma 10, this state of B is also reached by first reading b forwards, and then a forwards: $(\{1, 4\} \cdot b) \cdot a = \{0\}$. This in turn means by Lemma 14 that the word ba is accepted from state p , but not from state s , since $\{0\} \in p \setminus s$. Thus, states p , and s cannot be equivalent. \square

References

1. Brzozowski, J.A.: Derivatives of regular expressions. J. ACM 11, 481–494 (1964)
2. Brzozowski, J.A.: Canonical regular expressions and minimal state graphs for definite events. In: Mathematical Theory of Automata, MRI Symposia Series, vol. 12, pp. 529–561. Polytechnic Press, NY (1962)

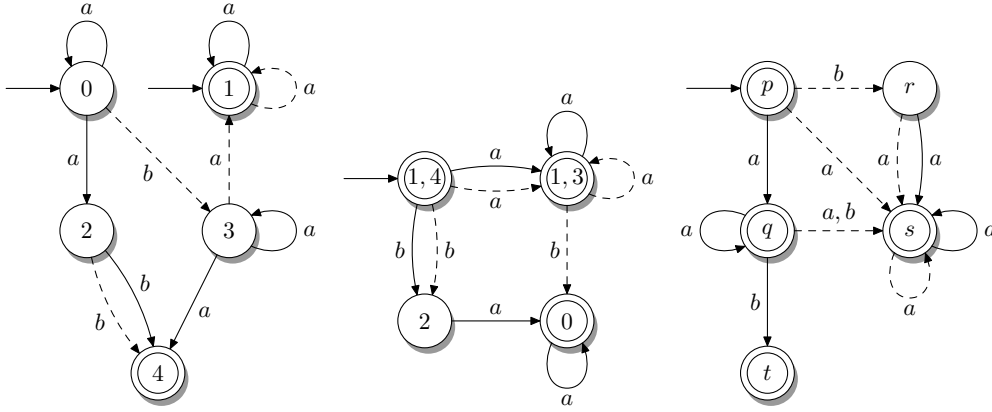

Fig. 7. Left: The nondeterministic biautomaton A with the \diamond - and the F -property. Middle: The deterministic biautomaton $B = \mathcal{P}(A^R)$, with the \diamond - and the I -property. Right: The minimal deterministic biautomaton $C = \mathcal{P}(B^R)$ with the \diamond - and F -property. The state symbols p, q, r, s, t are abbreviations for subsets of the state set of B . It is $p = \{\{0\}, \{1, 3\}, \{1, 4\}\}$, $q = \{\{0\}, \{2\}, \{1, 3\}, \{1, 4\}\}$, $r = \{\{1, 3\}\}$, $s = \{\{1, 3\}, \{1, 4\}\}$, and $t = \{\{1, 4\}\}$. The sink state \emptyset in the biautomata B and C and transitions leading to it are not shown.

3. Champarnaud, J.-M., Dubernard, J.-P., Jeanne, H., Mignot, L.: Two-sided derivatives for regular expressions and for hairpin expressions. arXiv:1301.3316v1 [cs.FL] (2012)
4. Jirásková, G., Klíma, O.: Descriptive complexity of biautomata. In: Kutrib, M., Moreira, N., Reis, R. (eds.) Proceedings of the 14th International Workshop Descriptive Complexity of Formal Systems. LNCS, vol. 7386, pp. 196–208. Springer, Braga, Portugal (2012)
5. Klíma, O., Polák, L.: On biautomata. RAIRO–Informatique théorique et Applications / Theoretical Informatics and Applications 46(4), 573–592 (2012)
6. Loukanova, R.: Linear context free languages. In: Jones, C.B., Liu, Z., Woodcock, J. (eds.) Proceedings of the 4th International Colloquium Theoretical Aspects of Computing. LNCS, vol. 4711, pp. 351–365. Springer, Macau, China (2007)
7. Pin, J.-E.: Handbook of Formal Languages, Vol. 1, Word, Language, Grammar, vol. 1, chap. Syntactic Semigroups, pp. 679–746. Springer (1997)
8. Rosenberg, A.L.: A machine realization of the linear context-free languages. Inform. Control 10, 175–188 (1967)



Recent Reports

(Further reports are available at www.informatik.uni-giessen.de.)

- A. Malcher, K. Meckel, C. Mereghetti, B. Palano, *Descriptive Complexity of Pushdown Store Languages*, Report 1203, May 2012.
- M. Holzer, S. Jakobi, *On the Complexity of Rolling Block and Alice Mazes*, Report 1202, March 2012.
- M. Holzer, S. Jakobi, *Grid Graphs with Diagonal Edges and the Complexity of Xmas Mazes*, Report 1201, January 2012.
- H. Gruber, S. Gulan, *Simplifying Regular Expressions: A Quantitative Perspective*, Report 0904, August 2009.
- M. Kutrib, A. Malcher, *Cellular Automata with Sparse Communication*, Report 0903, May 2009.
- M. Holzer, A. Maletti, *An $n \log n$ Algorithm for Hyper-Minimizing States in a (Minimized) Deterministic Automaton*, Report 0902, April 2009.
- H. Gruber, M. Holzer, *Tight Bounds on the Descriptive Complexity of Regular Expressions*, Report 0901, February 2009.
- M. Holzer, M. Kutrib, and A. Malcher (Eds.), *18. Theorietag Automaten und Formale Sprachen*, Report 0801, September 2008.
- M. Holzer, M. Kutrib, *Flip-Pushdown Automata: Nondeterminism is Better than Determinism*, Report 0301, February 2003.
- M. Holzer, M. Kutrib, *Flip-Pushdown Automata: $k + 1$ Pushdown Reversals are Better Than k* , Report 0206, November 2002.
- M. Holzer, M. Kutrib, *Nondeterministic Descriptive Complexity of Regular Languages*, Report 0205, September 2002.
- H. Bordihn, M. Holzer, M. Kutrib, *Economy of Description for Basic Constructions on Rational Transductions*, Report 0204, July 2002.
- M. Kutrib, J.-T. Löwe, *String Transformation for n -dimensional Image Compression*, Report 0203, May 2002.
- A. Klein, M. Kutrib, *Grammars with Scattered Nonterminals*, Report 0202, February 2002.
- A. Klein, M. Kutrib, *Self-Assembling Finite Automata*, Report 0201, January 2002.
- M. Holzer, M. Kutrib, *Unary Language Operations and its Nondeterministic State Complexity*, Report 0107, November 2001.
- A. Klein, M. Kutrib, *Fast One-Way Cellular Automata*, Report 0106, September 2001.
- M. Holzer, M. Kutrib, *Improving Raster Image Run-Length Encoding Using Data Order*, Report 0105, July 2001.
- M. Kutrib, *Refining Nondeterminism Below Linear-Time*, Report 0104, June 2001.
- M. Holzer, M. Kutrib, *State Complexity of Basic Operations on Nondeterministic Finite Automata*, Report 0103, April 2001.
- M. Kutrib, J.-T. Löwe, *Massively Parallel Fault Tolerant Computations on Syntactical Patterns*, Report 0102, March 2001.
- A. Klein, M. Kutrib, *A Time Hierarchy for Bounded One-Way Cellular Automata*, Report 0101, January 2001.
- M. Kutrib, *Below Linear-Time: Dimensions versus Time*, Report 0005, November 2000.
- M. Kutrib, *Efficient Universal Pushdown Cellular Automata and their Application to Complexity*, Report 0004, August 2000.
- M. Kutrib, J.-T. Löwe, *Massively Parallel Pattern Recognition with Link Failures*, Report 0003, June 2000.